

CLAMPING TECHNOLOGY FOR THE ENERGY SECTOR

The crude oil and natural gas industries are still the center of the worldwide energy production today. The extraction and further processing of these two raw materials require top precision and maximum safety. Technically advanced products, such as the air-operated self-contained chucks with through-hole from RÖHM, allow reliable machining of a wide range of workpieces at the top safety standard.

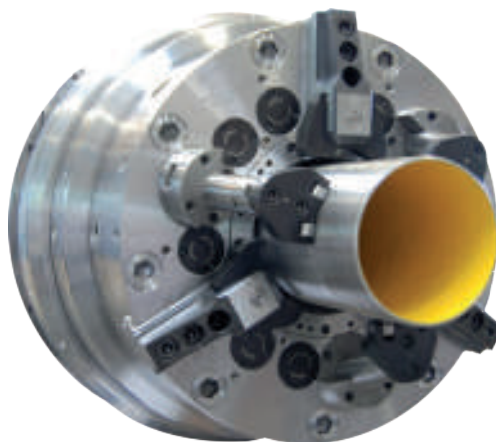

Video LVE



AIR-OPERATED SELF-CONTAINED CHUCKS

Air-operated self-contained chucks LVE are optimally suited for machining the ends of pipes, especially large and long pipes like the ones used for extracting crude oil or natural gas. For this, a chuck is mounted to the front and rear sides of the machine spindle. This combination allows large chip-cutting performance with high workpiece precision.

ADVANTAGES AT A GLANCE

- ⊕ Large through-hole optimal for machining pipes and bars
- ⊕ Cylinders integrated in the power chuck for flexible range of applications
- ⊕ Wedge hook system for high load capacity and clamping precision

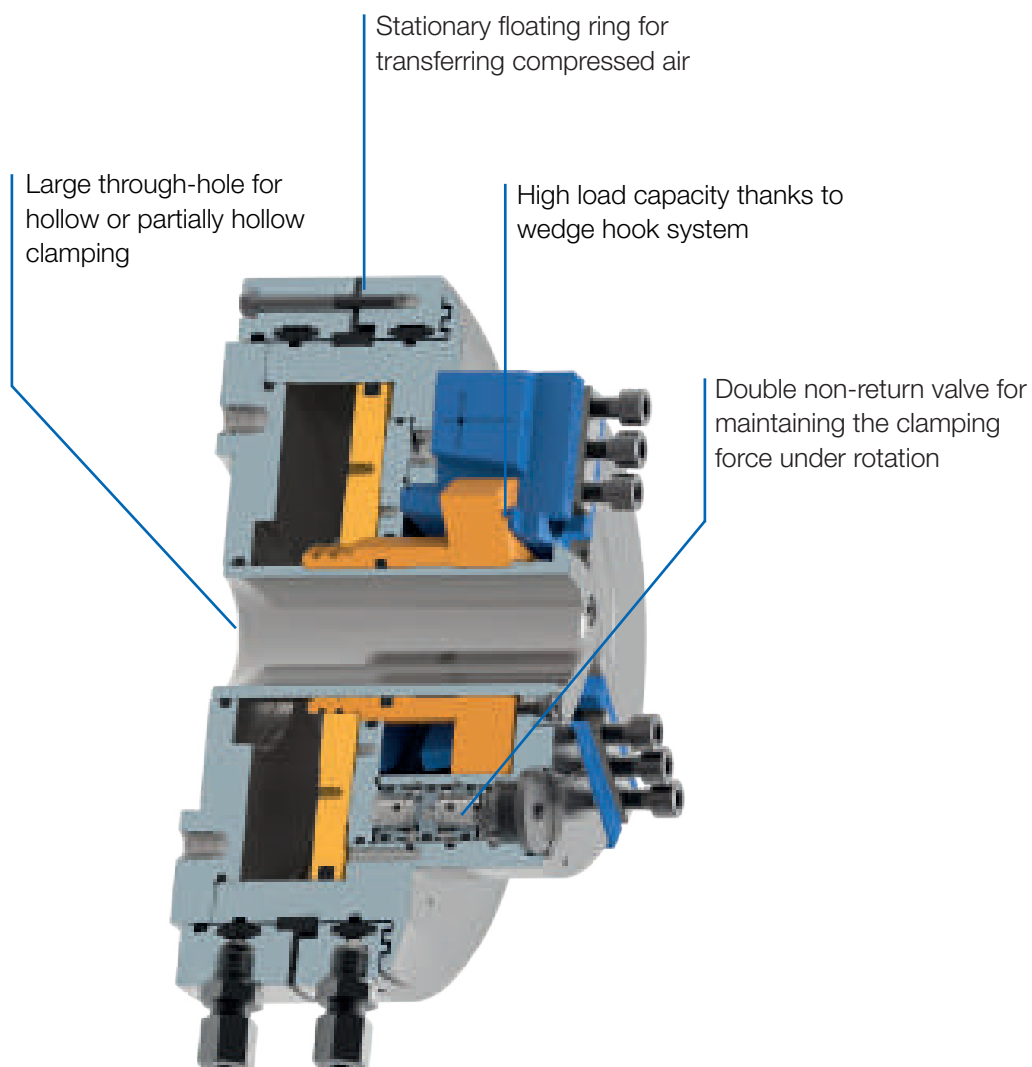



Air-operated self-contained chucks

LVE - with integrated pneumatic cylinder



APPLICATION

Optimally suited for flange, bar and tube machining, especially for machines without a clamping cylinder.

TYPE

Power chuck with integrated pneumatic cylinder and cylindrical centre mount. 3-jaw version with serration 90°.

CUSTOMER BENEFITS

- ⊕ Large through-hole
- ⊕ Can be easily exchanged with manual clamping chuck
- ⊕ Compact system dimensions because it is self-contained
- ⊕ Unobstructed bore through spindle thanks to omission of the draw tube
- ⊕ High clamping force already at 6 bar

TECHNICAL FEATURES

- Clamping and unclamping only when spindle at standstill
- Wedge hook system with integrated clamping cylinder

Included in scope of delivery:

Chuck, chuck and jaw mounting screws, slot nuts (without top jaws)

LVE = air-operated, self-contained chuck

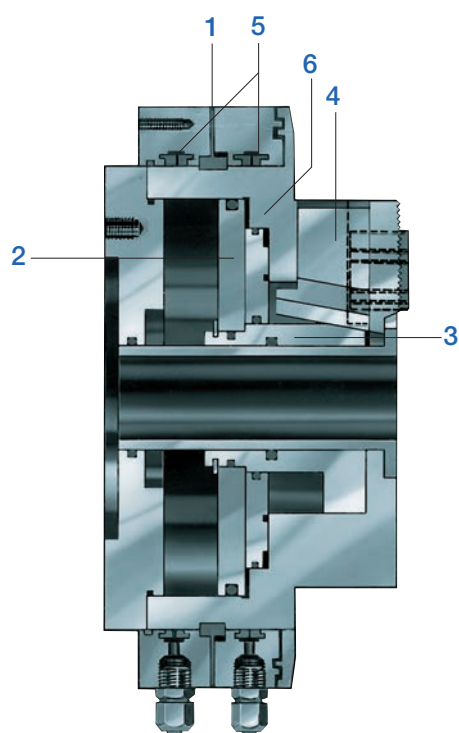

Mode of operation:

The compressed air is conducted through the stationary floating ring **1** via a double non-return valve into one of the two pressure chambers. The force acting on the pressure piston **2** is transferred through the clamping piston to the base jaws **4** via the proven wedge hook system **3**. During the clamping and unclamping operation, profile seals **5** seal off the floating ring **1** from the body **6**. After the clamping operation is finished, the pressure in the chuck body is maintained by the valve, whereby the supply lines are depressurized. The profile seals lift up due to their elasticity and are not damaged by the rotating chuck body.

Components:

1. Floating ring
2. Pressure piston
3. Wedge system
4. Base jaws
5. Special seals
6. Body



Air-operated self-contained chucks

LVE up to 10 bar, cylindrical centre Mount, serration 90°

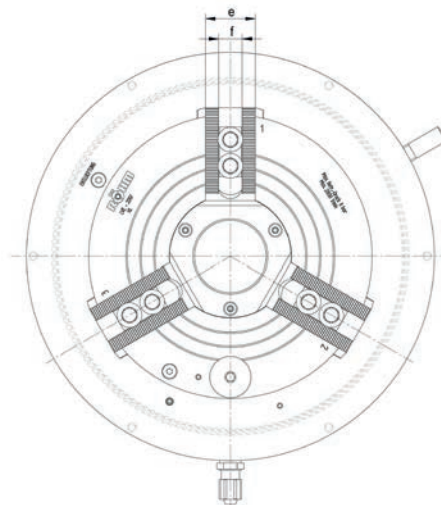
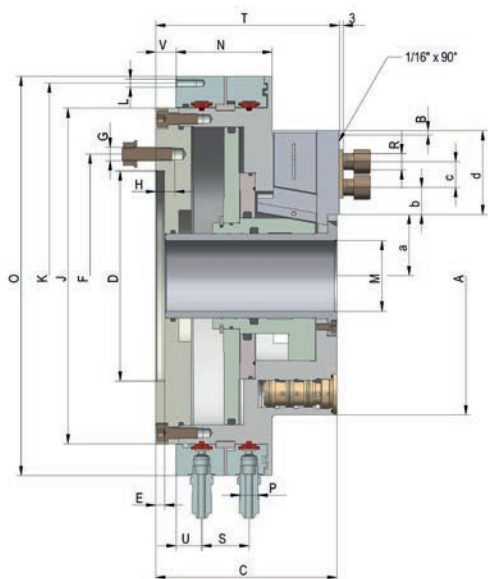

C 15

3-jaw self-contained chucks LVE, with through-hole, max. operating pressure 8 bar, with serration, cylindrical centre mount

Item No.	420189	420190	420191 ▲	420192 ▲	420193 ▲
Size	125	160	200	250	315
A mm	136	168	205	255	320
Jaw travel B mm	3	4,2	4,2	5	5
C mm	101,5	130,5	134	146	156,5
D ⁶ mm	120	125	155	185	225
E mm	6	6,5	6,5	6,5	6,5
F mm	137	150	180	210	250
G	M 8	M 10	M 10	M 10	M 10
H mm	8	13	14	14	14
J mm	164	205	248	315	350
K mm	190	235	285	358	388
L	M 6	M 6	M 6	M 6	M 16
M mm	26	38	52	68	90
N mm	66,5	80,5	71	78,5	79,5
O mm	204	250	295	370	400
P mm	R 1/4"	R 1/4"	R 1/4"	R 1/4"	R 1/4"
R	M 8	M 8	M 12	M 16	M 6
S mm	32	41	35	37	36
T mm	103	131,5	134	147,5	158
U mm	20	20,7	19	19	18
V mm	-	4	15	15,5	25
a min.	24	31,8	41,2	50	61,5
a max.	27	36	45,4	55	66,5
b min.	10	10	13	15	14,5
b max.	21	19,5	35	43	64
c mm	min. 14 / max. 25	2 x 15	19	25	25
d mm	41	49,5	62	78	99
e mm	25	32	36	44	44
f ^{H7} mm	12	12	17	21	21
Max. operating pressure bar	8	8	8	8	8
Min. operating pressure bar	2	2,5	2,5	2,5	2,5
Total clamping force at 6 bar kN	20	35	60	95	120
Max. admissible speed min ⁻¹	4000	3500	2800	2200	1800
Moment of inertia J kgm ²	0,028	0,125	0,262	0,675	1,35
Air consumption/jaw travel at 6 bar NL	1,5	2,4	3,9	6,6	8,2
Weight without jaws approx. kg	13	25	36	57	85

Higher speeds by fastening the stationary floating ring

LVE chuck with short taper mount ISO 702-3 (DIN 55027, studs and locknuts) on request

LVE chuck with short taper mount ISO 702-2 (DIN55029, studs for Camlock) on request



Air-operated self-contained chucks

Jaws LVE

C 21

Reversible top jaws, 3-jaw set, hardened serration 90° - material: 16MnCr5



Item no.	Chuck Size	Jaw length mm	Jaw height mm	Jaw width mm	Serration
046404	125/160	56	37,5	26	1/16"x 90°
118522	200	75	49	36	1/16"x 90°
046414	250/315	103,5	58	50	1/16"x 90°

Additionally or later applied, hardened jaws must be ground out in the chuck.

C 21

Soft top jaws, 3-jaw set, can be hardened serration 90° - material: 16MnCr5



Item no.	Chuck Size	Jaw length mm	Jaw height mm	Jaw width mm	Serration
046403	125/160	55	38	26,5	1/16"x 90°
133153	200	75	53	36,5	1/16"x 90°
133154	250/315	95	54,5	45	1/16"x 90°

Accessories LVE

C 15 Extended T-nuts

With screw

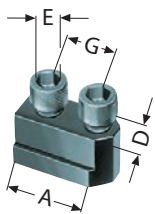

Item no.	Chuck Size	Con- tents of delivery	D mm	E	G mm
241673 ¹⁾	125	piece	12	M8x20	-
1305178 ▲	160	piece	12	M8x25	2x15
1305179	200	piece	17	M12x30	19
1305180 ▲	250/315	piece	21	M16x35	25

¹⁾ Metric dimensions



Air-operated self-contained chucks

Accessories LVE

C 15
Electro-pneumatic safety control block for LVE 125-315



Item no.	Voltage
437747	220 V 50 Hz
437748	24 V Dc

Please order accessories and connection hoses separately

C 15
Manual pulse generator, without cable



Item no.	Contents of delivery
220629 ▲	piece

C 15
Double foot-control switch



Item no.	Contents of delivery
249325 ▲	piece

C 15
Service unit



Item no.	Contents of delivery
367444 ¹⁾ ▲	piece

¹⁾ Consisting of filter, water separator and oiler, R 3/8"

C 15
Connector



Item no.	Chuck Size	Design	Contents of delivery
720233	125-200	snap-on connector CX-R 1/4"-PX-6	piece
720235	125-200	swivel connector LCX-R 1/4"-PX-6	piece
720260	250-315	straight screw-in unions Ø 12/9 R 1/4"	piece
720261	250-315	swivel connector Ø 12/9 R 1/4"	piece



Technical data

Jaw dimensions und chucking capacities LVE

Reversible top jaws UB,
hardened, serration 90°,
material 16MnCr5

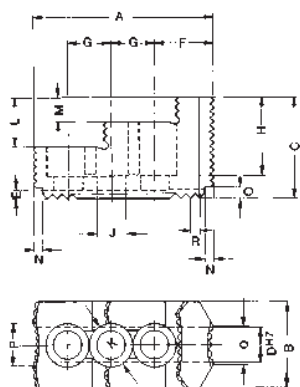

Chuck size	125	160	200	250	315
Type	538-02	538-02	538-04	538-05	538-05
Item no. 3-jaw set	046404	046404	118522	046414	046414
A	56	56	75	103,5	103,5
B	26	26	36	50	50
C	37,5	37,5	49	58	58
DH7	12	12	17	21	21
E	3,5	3,5	5	5	5
F	14	14	21,5	33,5	33,5
G	15	15	19	25	25
H	29	29	37,5	45	45
J	8,4	8,4	13	17	17
K	13,5	13,5	19	25	25
L	20	20	24	28	28
M	10	10	12	14	14
N	4	4	6	6	6
O	4	4	7,5	6,5	6,5
P	5	5	18	24,5	24,5
Q	5	5	7	22,5	22,5
R	1/16"x90°	1/16"x90°	1/16"x90°	1/16"x90°	1/16"x90°
Weight/jaw kg	0,170	0,170	0,460	1,130	1,130

Soft top jaws AB,
material 16MnCr5

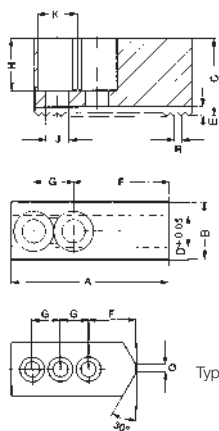

Chuck size	125	160	200	250	250
Type	538-02	538-02	538-04	538-05	538-05
Item no. 3-jaw set	046403	046403	133153	133154	133154
A	55	55	75	95	95
B	26,5	26,5	36,5	45	45
C	38	38	53	54,5	54,5
DH7	12	12	17	21	21
E	3,5	3,5	5	5	5
F	31	31	44	55	55
G	15	15	19	25	25
H	28	28	43	42,5	42,5
J	8,4	8,4	13	17	17
K	13,5	13,5	19	25	25
R	1/16"x90°	1/16"x90°	1/16"x90°	1/16"x90°	1/16"x90°
Weight/jaw kg	0,320	0,320	0,880	1,400	1,400

Jaw dimensions und
Chucking capacities

Chucking capacities with reversible
top jaws UB

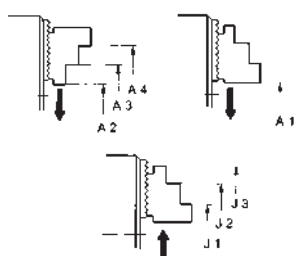

Chuck size		125	160	200	250	315
with reversible jaws	Type	538-02	538-02	538-04	538-05	538-05
	Jaw position					
External chucking	A1	12-63	28-80	30-115	20-128	41-194
	A2	17-69	32-84	44-128	46-154	67-220
	A3	67-119	82-132	101-185	128-238	150-303
	A4	101-153	118-168	152-236	210-318	231-384
Internal chucking	J1	49-99	64-116	80-165	70-188	91-244
	J2	81-131	96-148	130-214	146-255	168-320
	J3	125-175	140-192	182-266	225-334	246-400



Notes

Notes



Air-operated self-contained chucks

LVE - large through-hole



APPLICATION

Optimal for the end machining of large and long pipes, e.g. for the oil and gas industry (especially as front and rear chuck).

TYPE

Power chuck with integrated pneumatic cylinder and cylindrical centre mount. 3-jaw version with serration 90°.

CUSTOMER BENEFITS

- ③ Extra-large through-hole
- ③ Can be easily exchanged with manual clamping chuck
- ③ Compact system dimensions because it is self-contained
- ③ Unobstructed bore through spindle thanks to omission of the draw tube
- ③ Flange and bar machining possible without retrofitting

TECHNICAL FEATURES

- Clamping and unclamping only when spindle at standstill
- Wedge hook system with integrated clamping cylinder
- Control valves maintain the clamping pressure during machining
- Short clamping cycle thanks to rapid and clamping stroke (optionally)
- Permanent monitoring of the clamping pressure while machining (optionally)

Note:

Other versions on request: e.g. front-end chucks for compensating clamping, compensating self-contained chucks and chucks that can be converted from self-centering to compensating.

Included in scope of delivery:

Chuck, chuck and jaw mounting screws, slot nuts (without top jaws)

LVE = air-operated, self-contained chuck

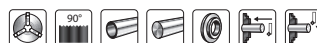

Possible application

Two chucks are mounted on the front and rear sides of the machine spindle. Via a selection switch on our electronic control unit DF type 525-90 combined with one pneumatic control unit LSV type 525-91 each, the two chucks can be used together or separately and also with different clamping pressures. This combinations make a high cutting capacity and high turning precision possible for the end machining of long pipes.

Air-operated self-contained chucks, sizes 400-1000

Characteristic for this chuck is a pneumatic piston integrated in the chuck body for generating the clamping force. To clamp or unclamp the workpiece, the compressed air is conducted to the pneumatic piston while the chuck is stationary via the distributor ring and non-return valve. The pneumatic piston is screwed to the clamping piston, with which, in turn, the base jaws are connected via a wedge hook system. An axial movement of the pneumatic piston therefore causes a radial movement of the base jaws.

Distributor ring

The distributor ring has the function of transferring compressed air from the outside into the chuck. This means that the distributor ring is always stationary, while the chuck rotates during workpiece machining. It is therefore mounted to the spindle box, and is therefore secured against rotating along. Special seals seal the gap between the distributor ring and chuck during the clamping operation so that the pressure can be transferred with no problems.

Important: To prevent the sealing ring from being destroyed, the pressure may only be transferred when the chuck is at a standstill.

Control valve

The control valve has the job of securing the compressed air required for clamping in a closed system throughout machining. It automatically secures that piston side which is pressurized, whereby the compressed air of the opposite-lying piston side is unclamped automatically. The valve can be dismantled as a complete unit and is available as replacement unit.



Air-operated self-contained chucks

LVE - large through-hole

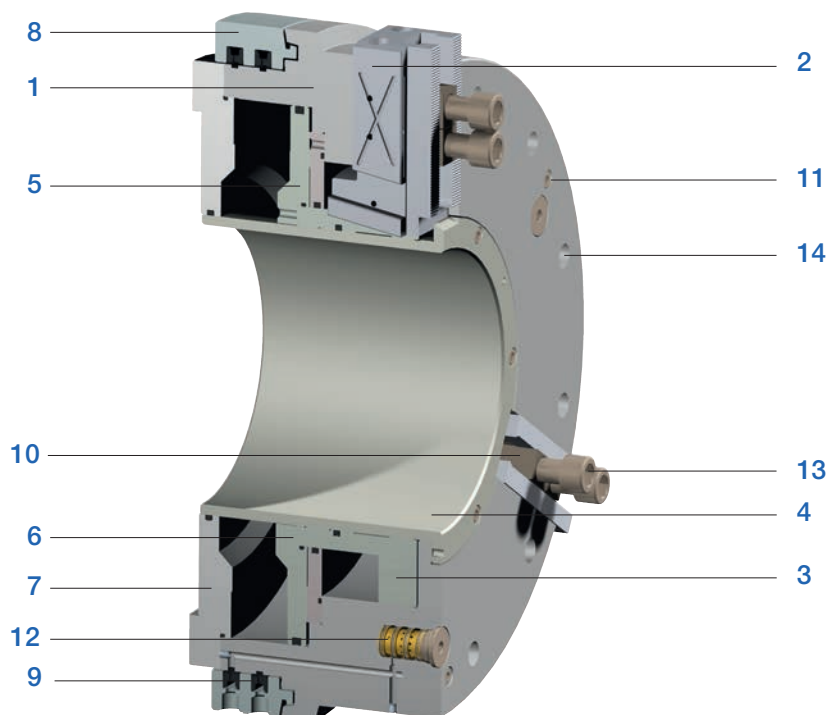

Components LVE

- 1. Body
- 2. Base jaw
- 3. Piston
- 4. Protective bush
- 5. Intermediate washer
- 6. Piston plate
- 7. Flange
- 8. Distributor ring
- 9. Seal
- 10. T-nut
- 11. Air-vent screw
- 12. Control valve
- 13. Jaw fixing screws
- 14. Chuck fixing screws

Control system

The clamping safety mainly depends on the leak-tightness of the closed pneumatic chamber. A pressure drop during machining causes a reduction in the clamping force.

The „RÖHM control system“ is used to control the pressure of the closed pneumatic chamber. If the pressure falls below a defined minimum level, a spring-loaded pin attached to the rear side of the chuck moves out to the rear.

At the same height as the pin, a contactless inductive probe is fastened at a certain radial distance. If the extended pin moves through the magnetic field of the probe, an electrical pulse is triggered, which can be used to shut the machine down.

Wedge hook system

The axial piston force is transferred and transmitted into the radial jaw force via the proven wedge hooks. The large force transfer surfaces guarantee a long service life and a sustainably high clamping precision. These features apply both to the chuck with normal jaw stroke as well as to chucks with rapid and gripping jaw movements.

RÖHM control system

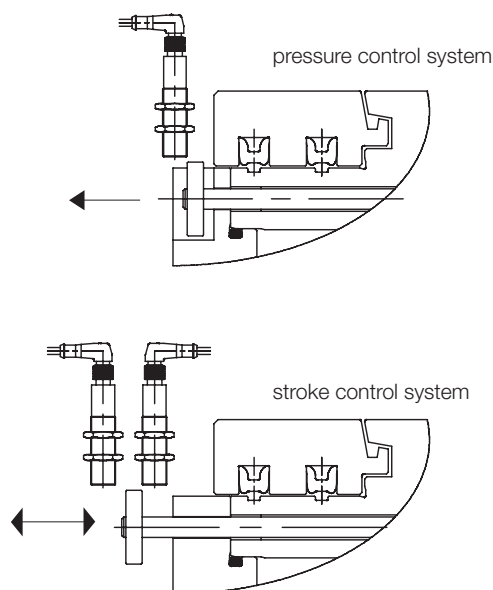

The control unit is designed for LVE chucks with rapid and clamping strokes only for external clamping. For LVE chucks with a normal stroke only pressure control device for the external clamping is provided (on customer demand for internal clamping).

Air-operated self-contained chuck LVE



Air-operated self-contained chucks

LVE - large through-hole, standard design

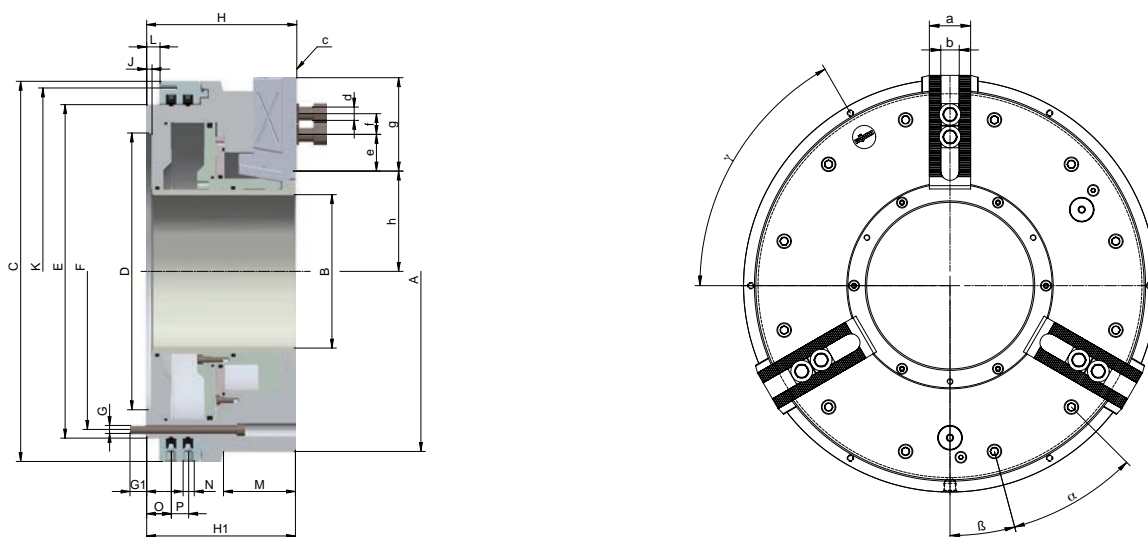

C 15
3-jaw self-contained chucks LVE, with large through-hole, max. operating pressure 8 bar, with serration
Cylindrical centre mount (standard version)

Item No.	169400 ▲	169401	169402 ▲	169403 ▲	169404 ▲	169405 ▲	169406 ▲	169407 ▲	169409 ▲
Size	400	400	500	500	600	600	600	700	800
LVE	LVE 420-140	LVE 480-185	LVE 540-205	LVE 570-230	LVE 600-275	LVE 640-275	LVE 680-325	LVE 730-375	LVE 830-410
Jaw travel mm	7	8,5	8,5	8,5	8,5	10	10	10	12
A mm	425	480	540	570	605	640	685	735	835
B mm	140	185	205	230	275	275	325	375	410
C mm	470	530	570	570	605	685	685	735	850
D ^Ø mm	310	365	415	415	450	510	510	560	700
E mm	400	460	500	500	535	610	610	660	775
F mm	374	434	474	474	508	580	580	630	745
G	M12	M12	M12	M12	M12	M16	M16	M16	M16
G1 mm	25	25	25	25	25	30	30	30	30
H mm	196	225	225	225	225	263	263	263	305
H1 mm	194	223	223	223	223	261	261	261	303
J mm	8	8	8	8	8	8	8	8	8
K mm (6xM8)	448	510	550	550	585	666	666	716	830
L mm	20	20	20	20	20	20	20	20	25
M mm	70	90	100	-	-	110	-	-	155
N	G 3/8	G 3/8	G 3/8	G 3/8	G 3/8	G 1/2	G 1/2	G 1/2	G 1/2
O mm	37	37	37	37	37	39,5	39,5	39,5	44,5
P mm	26	26	26	26	26	33	33	33	33
a mm	57	57	57	57	57	75	75	75	75
bH7 mm	25,5	25,5	25,5	25,5	25,5	30	30	30	30
c inch	3/32"x90°	3/32"x90°	3/32"x90°	3/32"x90°	3/32"x90°	3/32"x90°	3/32"x90°	3/32"x90°	3/32"x90°
d	M20x50	M20x50	M20x50	M20x50	M20x50	M24x60	M24x60	M24x60	M24x60
e mm	20	20	20	20	20	28	28	28	28
f min.	32	32	32	32	32	42	42	42	42
f max.	85	85	105	105	100	100	100	100	125
g mm	120	120	140	140	135	145	145	145	173
h min.	94	118,5	129	141,5	164	175	195	220	242,5
h max.	101	127	137,5	150	172,5	185	205	230	254,5
α degree	30°	30°	30°	30°	30°	30°	30°	30°	30°
β degree	15°	15°	15°	15°	15°	15°	15°	15°	15°
γ degree	60°	60°	60°	60°	60°	60°	60°	60°	60°
Min. operating pressure bar	2	2	2	2	2	2	2	2	3
Max. operating pressure bar	8	8	8	8	8	8	8	8	8
Total clamping force at 6 bar kN	140	155	210	190	200	240	180	205	325
Cylinder surface area cm ²	710	899	1045	940	1010	1414	1181	1341	2121
Air consumption (total stroke) l	20	31	36	32	35	58	49	55	104
Max. admissible speed min ⁻¹	1700	1500	1300	1300	1200	1000	900	800	750
Moment of inertia kgm ²	3.50	7.00	10.50	12.50	15.50	24.75	29.50	38.50	76.25
Weight kg	150	215	263	272	289	423	426	470	723

Air-operated self-contained chuck LVE



Air-operated self-contained chucks

LVE - large through-hole, with pressure control device

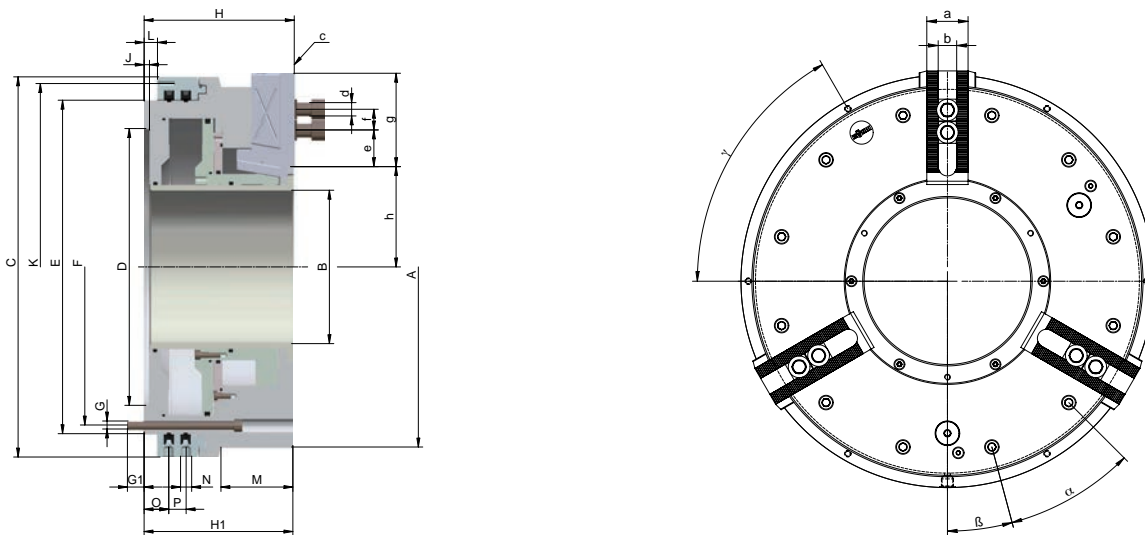

C 15
3-jaw self-contained chucks LVE, with large through-hole, max. operating pressure 8 bar, with serration
Cylindrical centre mount with pressure control device for external clamping

Item No.	169411 ▲	169412 ▲	169413 ▲	169414 ▲	169415 ▲	169416 ▲	169417 ▲	169418 ▲	169420 ▲
Size	400	400	500	500	600	600	600	700	800
LVE	LVE 420-140	LVE 480-185	LVE 540-205	LVE 570-230	LVE 600-275	LVE 640-275	LVE 680-325	LVE 730-375	LVE 830-410
Jaw travel mm	7	8,5	8,5	8,5	8,5	10	10	10	12
A mm	425	480	540	570	605	640	685	735	835
B mm	140	185	205	230	275	275	325	375	410
C mm	470	530	570	570	605	685	685	735	850
D ⁶ mm	310	365	415	415	450	510	510	560	700
E mm	400	460	500	500	535	610	610	660	775
F mm	374	434	474	474	508	580	580	630	745
G	M12	M12	M12	M12	M12	M16	M16	M16	M16
G1 mm	25	25	25	25	25	30	30	30	30
H mm	196	225	225	225	225	263	263	263	305
H1 mm	194	223	223	223	223	261	261	261	303
J mm	8	8	8	8	8	8	8	8	8
K mm (6xM8)	448	510	550	550	585	666	666	716	830
L mm	20	20	20	20	20	20	20	20	25
M mm	70	90	100	-	-	110	-	-	155
N	G 3/8	G 3/8	G 3/8	G 3/8	G 3/8	G 1/2	G 1/2	G 1/2	G 1/2
O mm	37	37	37	37	37	39,5	39,5	39,5	44,5
P mm	26	26	26	26	26	33	33	33	33
a mm	57	57	57	57	57	75	75	75	75
bH7 mm	25,5	25,5	25,5	25,5	25,5	30	30	30	30
c inch	3/32"x90°	3/32"x90°	3/32"x90°	3/32"x90°	3/32"x90°	3/32"x90°	3/32"x90°	3/32"x90°	3/32"x90°
d	M20x50	M20x50	M20x50	M20x50	M20x50	M24x60	M24x60	M24x60	M24x60
e mm	20	20	20	20	20	28	28	28	28
f min.	32	32	32	32	32	42	42	42	42
f max.	85	85	105	105	100	100	100	100	125
g mm	120	120	140	140	135	145	145	145	173
h min.	94	118,5	129	141,5	164	175	195	220	242,5
h max.	101	127	137,5	150	172,5	185	205	230	254,5
α degree	30°	30°	30°	30°	30°	30°	30°	30°	30°
β degree	15°	15°	15°	15°	15°	15°	15°	15°	15°
γ degree	60°	60°	60°	60°	60°	60°	60°	60°	60°
Min. operating pressure bar	2	2	2	2	2	2	2	2	3
Max. operating pressure bar	8	8	8	8	8	8	8	8	8
Total clamping force at 6 bar kN	140	155	210	190	200	240	180	205	325
Cylinder surface area cm ²	710	899	1045	939	1010	1414	1181	1341	2121
Air consumption (total stroke) l	20	31	36	32	35	58	49	55	104
Max. admissible speed min ⁻¹	1700	1500	1300	1300	1200	1000	900	800	750
Moment of inertia kgm ²	3.50	7.00	10.50	12.50	15.5	24.75	29.50	38.50	76.25
Weight kg	150	215	263	272	289	423	426	470	723

Air-operated self-contained chuck LVE



Air-operated self-contained chucks

LVE - large through-hole, standard design, with rapid and clamping jaw movement

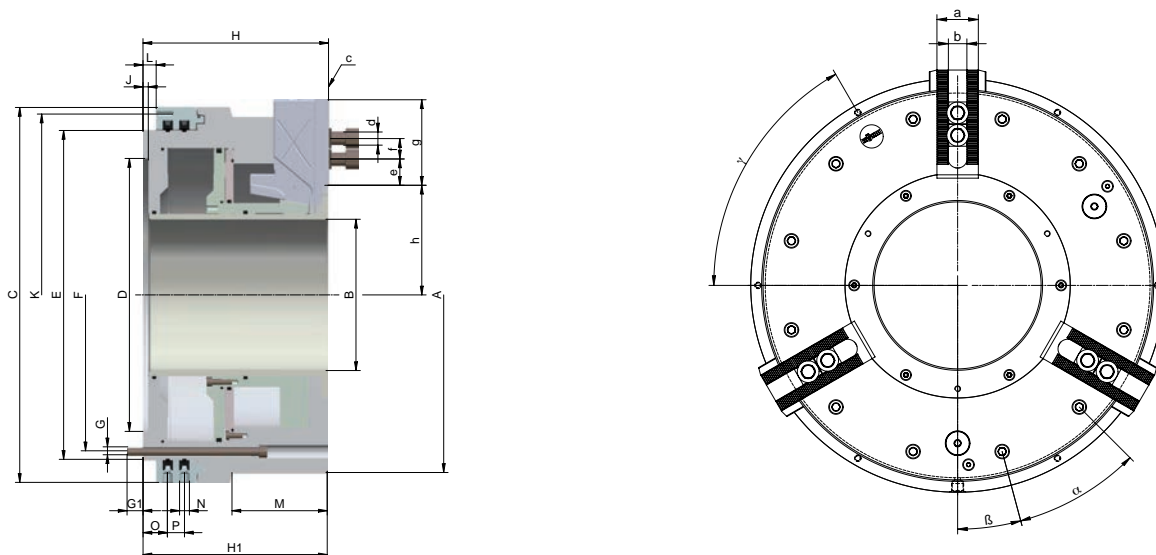

C 15
3-jaw self-contained chucks LVE, with rapid and clamping jaw movements, with large through-hole, external chucking, max. operating pressure 8 bar, with serration
Cylindrical centre mount (standard version)

Item No.	169422 ▲	169423	169424 ▲	169425 ▲	169426 ▲	169427 ▲	169428 ▲	169429 ▲	169431 ▲
Size	400	400	500	500	600	600	600	700	800
LVE	LVE 470-140 ES	LVE 490-185 ES	LVE 570-205 ES	LVE 570-230 ES	LVE 600-275 ES	LVE 640-275 ES	LVE 680-325 ES	LVE 730-375 ES	LVE 850-410 ES
Jaw travel mm	19	25,4	25,4	25,4	25,4	25,4	25,4	25,4	25,4
Rapid movement mm	12	16,9	16,9	16,9	16,9	16,9	16,9	16,9	14,9
clamping movement mm	7	8,5	8,5	8,5	8,5	8,5	8,5	8,5	10,5
A mm	470	490	570	570	605	645	685	735	850
B mm	140	185	205	230	275	275	325	375	410
C mm	470	530	570	570	605	685	685	735	850
D ^Ø mm	310	365	415	415	450	510	510	560	700
E mm	400	460	500	500	535	610	610	660	775
F mm	374	434	474	474	508	580	580	630	745
G	M12	M12	M12	M12	M12	M16	M16	M16	M16
G1 mm	25	25	25	25	25	30	30	30	30
H mm	240	282	282	282	282	308	308	308	322
H1 mm	238	280	280	280	280	306	306	306	320
J mm	8	8	8	8	8	8	8	8	8
K mm (6xM8)	448	510	550	550	585	666	666	716	830
L mm	20	20	20	20	20	20	20	20	25
M mm	-	140	-	-	-	150	-	-	-
N	G 3/8	G 3/8	G 3/8	G 3/8	G 3/8	G 1/2	G 1/2	G 1/2	G 1/2
O mm	37	37	37	37	37	39,5	39,5	39,5	44,5
P mm	26	26	26	26	26	33	33	33	33
a mm	57	57	57	57	57	75	75	75	75
bH7 mm	25,5	25,5	25,5	25,5	25,5	30	30	30	30
c inch	3/32"x90°	3/32"x90°	3/32"x90°	3/32"x90°	3/32"x90°	3/32"x90°	3/32"x90°	3/32"x90°	3/32"x90°
d	M20x50	M20x50	M20x50	M20x50	M20x50	M24x60	M24x60	M24x60	M24x60
e mm	20	20	20	20	20	28	28	28	28
f min.	32	32	32	32	32	42	42	42	42
f max.	80	80	95	95	90	95	95	95	120
g mm	112	112	130	130	125	140	140	140	170
h min.	126	132,6	142,1	154,6	177,1	182,6	202,6	227,6	234,6
h max.	145	158	167,5	180	202,5	208	228	253	260
α degree	30°	30°	30°	30°	30°	30°	30°	30°	30°
β degree	15°	15°	15°	15°	15°	15°	15°	15°	15°
γ degree	60°	60°	60°	60°	60°	60°	60°	60°	60°
Min. operating pressure bar	2	2	2	2	2	2	2	2	3
Max. operating pressure bar	8	8	8	8	8	8	8	8	8
Total clamping force at 6 bar kN	120	150	190	170	180	185	180	200	325
Cylinder surface area cm ²	700	862	1003	895	958	1203	1181	1307	2121
Air consumption (total stroke) l	32	42	48	45	46	58	57	63	113
Max. admissible speed min ⁻¹	1500	1300	1200	1200	1100	900	800	750	750
Moment of inertia kgm ²	6.50	8.75	15.50	15.00	19.00	30.50	35.25	45.75	84.50
Weight kg	200	267	348	334	356	515	505	554	785

Air-operated self-contained chuck LVE



Air-operated self-contained chucks

LVE - large through-hole, with pressure control device, rapid and clamping jaw movement

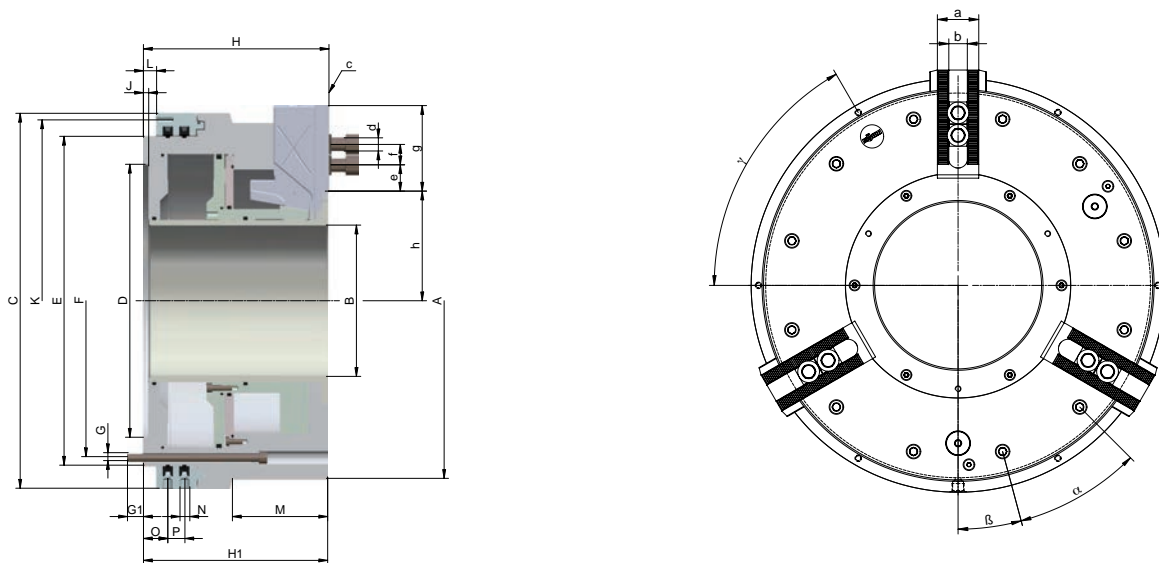

C 15
3-jaw self-contained chucks LVE, with rapid and gripping jaw movements, with large through-hole, external chucking, max. operating pressure 8 bar, with serration
Cylindrical centre mount with pressure control device for external clamping

Item No.	169433 ▲	169434 ▲	169435 ▲	169436 ▲	169437 ▲	169438 ▲	169439 ▲	169440 ▲	169442 ▲
Size	400	400	500	500	600	600	600	700	800
LVE	LVE 470-140 ES	LVE 490-185 ES	LVE 570-205 ES	LVE 570-230 ES	LVE 600-275 ES	LVE 640-275 ES	LVE 680-325 ES	LVE 730-375 ES	LVE 850-410 ES
Jaw travel mm	19	25,4	25,4	25,4	25,4	25,4	25,4	25,4	25,4
Rapid movement mm	12	16,9	16,9	16,9	16,9	16,9	16,9	16,9	14,9
Gripping movement mm	7	8,5	8,5	8,5	8,5	8,5	8,5	8,5	10,5
A mm	470	490	570	570	605	645	685	735	850
B mm	140	185	205	230	275	275	325	375	410
C mm	470	530	570	570	605	685	685	735	850
D ⁶ mm	310	365	415	415	450	510	510	560	700
E mm	400	460	500	500	535	610	610	660	775
F mm	374	434	474	474	508	580	580	630	745
G	M12	M12	M12	M12	M12	M16	M16	M16	M16
G1 mm	25	25	25	25	25	30	30	30	30
H mm	240	282	282	282	282	308	308	308	322
H1 mm	238	280	280	280	280	306	306	306	320
J mm	8	8	8	8	8	8	8	8	8
K mm (6xM8)	448	510	550	550	585	666	666	716	830
L mm	20	20	20	20	20	20	20	20	25
M mm	-	140	-	-	-	150	-	-	-
N	G 3/8	G 3/8	G 3/8	G 3/8	G 3/8	G 1/2	G 1/2	G 1/2	G 1/2
O mm	37	37	37	37	37	39,5	39,5	39,5	44,5
P mm	26	26	26	26	26	33	33	33	33
a mm	57	57	57	57	57	75	75	75	75
bH7 mm	25,5	25,5	25,5	25,5	25,5	30	30	30	30
c inch	3/32"x90°	3/32"x90°	3/32"x90°	3/32"x90°	3/32"x90°	3/32"x90°	3/32"x90°	3/32"x90°	3/32"x90°
d	M20x50	M20x50	M20x50	M20x50	M20x50	M24x60	M24x60	M24x60	M24x60
e mm	20	20	20	20	20	28	28	28	28
f min.	32	32	32	32	32	42	42	42	42
f max.	80	80	95	95	90	95	95	95	120
g mm	112	112	130	130	125	140	140	140	170
h min.	126	132,6	142,1	154,6	177,1	182,6	202,6	227,6	234,6
h max.	145	158	167,5	180	202,5	208	228	253	260
α degree	30°	30°	30°	30°	30°	30°	30°	30°	30°
β degree	15°	15°	15°	15°	15°	15°	15°	15°	15°
γ degree	60°	60°	60°	60°	60°	60°	60°	60°	60°
Min. operating pressure bar	2	2	2	2	2	2	2	2	3
Max. operating pressure bar	8	8	8	8	8	8	8	8	8
Total clamping force at 6 bar kN	120	150	210	170	180	185	180	200	325
Cylinder surface area cm ²	700	862	1024	895	958	1203	1181	1307	2121
Air consumption (total stroke) l	32	42	50	45	46	58	57	63	113
Max. admissible speed min ⁻¹	1500	1300	1200	1200	1100	900	800	750	750
Moment of inertia kgm ²	6,50	8,75	15,50	15,00	19,00	30,50	35,25	45,75	84,50
Weight kg	200	267	348	334	356	515	505	554	785

Air-operated self-contained chuck LVE



Air-operated self-contained chucks

Jaws LVE

C 21

Reversible top jaws, 3-jaw set, hardened serration 90° - material: 16MnCr5

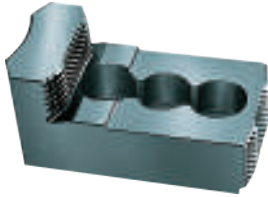

Chuck Size	3-jaw set	Jaw length mm	Jaw height mm	Jaw width mm	Serration
400/500/600	037531	135	65	68	3/32"x 90°
600/700	169464	170	75	80	3/32"x90°
800	169466	195	85	80	3/32"x90°

Additionally or later applied, hardened jaws must be ground out in the chuck.

C 21

Extended soft top jaws, 3-jaw set serration 90° - material: 16MnCr5



Chuck Size	3-jaw set	Jaw length mm	Jaw height mm	Jaw width mm	Serration
400	137028	180	80	50	3/32"x 90°
500/600	169449	205	80	50	3/32"x90°
600/700	169452	245	89	68	3/32"x90°
800	169456	285	89	68	3/32"x90°



Air-operated self-contained chucks

Accessories LVE

C 15 T-nuts
With screw

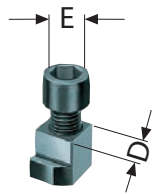

Item no.	Chuck Size	Contents of delivery	D mm	E
1305181 ▲	400/500/600	piece	25,5	M20x50
1305182 ▲	600/700/800/1000	piece	30	M24x60

C 15
Pneumatic control unit for LVE 400-1000



Item no.	Width mm	Height mm	Depth mm	Control voltage	Connection	Weight approx. kg
426560	280	250	100	24 V	R 1/2 inside thread	3

When double chucks are used, two pneumatic control devices are required

C 15
Control units for single chucks with dual foot switch, wired, cable length 6 meters, for LVE 400-1000



Item no.	Design	Width mm	Height with plug mm	Height mm	Depth mm	Control voltage	Cable length
426481	without pressure monitoring	300	340	300	125	24 V	6 m
426263	with pressure monitoring	300	340	300	125	24 V	6 m

Power supplies on request: primary 35-264 V ~, 47-63 Hz - secondary 24V/1.5 A

C 15
Control units for dual chucks with dual foot switch, wired, cable length 6 meters, for LVE 400-1000



Item no.	Design	Width mm	Height with plug mm	Height mm	Depth mm	Control voltage	Cable length
426482 ▲	without pressure monitoring	300	340	300	125	24 V	6 m
426264 ▲	with pressure monitoring	300	340	300	125	24 V	6 m

Power supplies on request: primary 35-264 V ~, 47-63 Hz - secondary 24V/1.5 A



Technical data

Jaw dimensions und chucking capacities LVE

Reversible top jawsUB
serration 90°,
material 16MnCr5

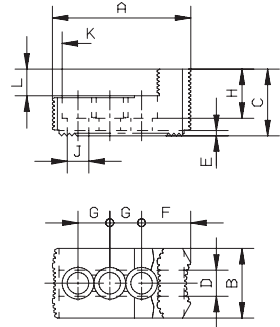

Chuck size	400		500		600		700	800			
LVE	420-140	480-185	540-205	570-230	600-275	630-275	680-325	730-375	800-375	830-410	
Type	538-07		538-07		538-07	543-21		543-21	543-21		
Item no. 3-jaw set	037531		037531		037531	169464		169464	169466		
A	135	135	135	135	135	170	170	170	195	195	
B	68	68	68	68	68	80	80	80	80	80	
C	65	65	65	65	65	75	75	75	85	85	
D+0,05	25,5	25,5	25,5	25,5	25,5	30,0	30,0	30,0	30,0	30,0	
E	5	5	5	5	5	6	6	6	6	6	
F	48	48	48	48	48	57	57	57	78,5	78,5	
G	31+31	31+31	31+31	31+31	31+31	42+42	42+42	42+42	42+42	42+42	
H	48	48	48	48	48	58	57	57	62	62	
J	21	21	21	21	21	25	25	25	26	26	
K	31	31	31	31	31	38	38	38	40	40	
L	26	26	26	26	26	32	32	32	35	35	
M	--	--	--	--	--	--	--	--	--	--	
Serration	3/32"x90°	3/32"x90°	3/32"x90°	3/32"x90°	3/32"x90°	3/32"x90°	3/32"x90°	3/32"x90°	3/32"x90°	3/32"x90°	
Weight/jaw kg	2,4	2,4	2,4	2,4	2,4	3,9	3,9	3,9	5,6	5,6	
External chucking	A1	85 - 255	135 - 305	160 - 370	180 - 390	220 - 430	225 - 420	265 - 460	315 - 510	280 - 530	315 - 565
	A2	125 - 295	175 - 345	200 - 410	220 - 430	260 - 470	275 - 470	315 - 510	365 - 560	370 - 620	405 - 655
	A3	330 - 500	380 - 550	405 - 615	425 - 635	465 - 675	540 - 735	580 - 775	630 - 825	640 - 890	675 - 925
Internal chucking	J1	155 - 325	205 - 375	230 - 440	250 - 460	290 - 500	305 - 500	345 - 540	395 - 590	405 - 655	440 - 690
	J2	350 - 520	405 - 570	430 - 640	450 - 660	490 - 700	565 - 770	605 - 800	655 - 850	670 - 920	705 - 955
max. interferences diameter	S	570	625	690	710	750	800	840	890	1000	1030

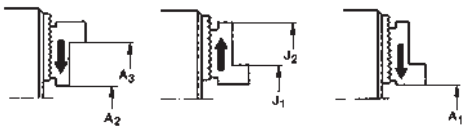

Extended soft top jaws AB
serration 90°,
material 16MnCr5

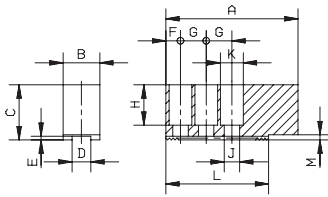

Chuck size	400		500		600		700	800		
LVE	420-140	480-185	540-205	570-230	600-275	640-275	680-325	730-375	800-375	830-410
Type	518-07		543-22		543-22	543-22		543-22	543-22	
Item no. 3-jaw	137028		169449		169449	169452		169452	169456	
A	180	180	205	205	205	245	245	245	285	285
B	50	50	50	50	50	68	68	68	68	68
C	80	80	80	80	80	89	89	89	89	89
D+0,05	25,5	25,5	25,5	25,5	25,5	30,0	30,0	30,0	30,0	30,0
E	5	5	5	5	5	6	6	6	6	6
F	20	20	20	20	20	25	25	25	25	25
G	35+35	35+35	35+35	35+35	35+35	45+45	45+45	45+45	55+55	55+55
H	60	60	60	60	60	69	69	69	69	69
J	21	21	21	21	21	25	25	25	25	25
K	31	31	31	31	31	37	37	37	37	37
L	180	180	190	190	190	140	140	140	160	160
M	--	--	6	6	6	7	7	7	7	7
Toothing	3/32"x90°	3/32"x90°	3/32"x90°	3/32"x90°	3/32"x90°	3/32"x90°	3/32"x90°	3/32"x90°	3/32"x90°	3/32"x90°
Weight/jaw kg	4,2	4,2	5,0	5,0	5,0	9,1	9,1	9,1	10,9	10,9
A1 Ø External chucking	20 - 155	30 - 200	10 - 220	30 - 240	75 - 285	60 - 255	100 - 295	150 - 345	105 - 355	140 - 390
S Ø max. interference diameter	330	575	640	660	710	760	800	850	945	980

Jaw dimensions und
Chucking capacities



Notes

Notes